

flextos[®]

SUPER CUT XPX

Basic milling and sawing table



The
**PERFECT
MACHINE**
to start with

work smart.

Your advantages with the SUPERCUT XPX Basic milling and sawing tables



perfect edges without sanding and filling



almost dust-free working = effective extraction



consistently best possible quality



added value remains in your company



savings in personnel, time and material/cuttings



quickly ready for use = profitable in shortest time



Features

- digital measuring system, electromagnetic fixation of the axis
- powerful engines
- modular table design for an extended working area (if necessary)
- flow-optimised, automatic, punctual vacuum unit
- automatic lifting unit
- shaped milling and plate cut-outs using template technology

Application

- milling and sawing, simple change of unit
- production of cut-outs and complex shaped parts
- machining of different panel materials
- one-man operation
- realisation of high quality and design demands

SUPER CUT XPX

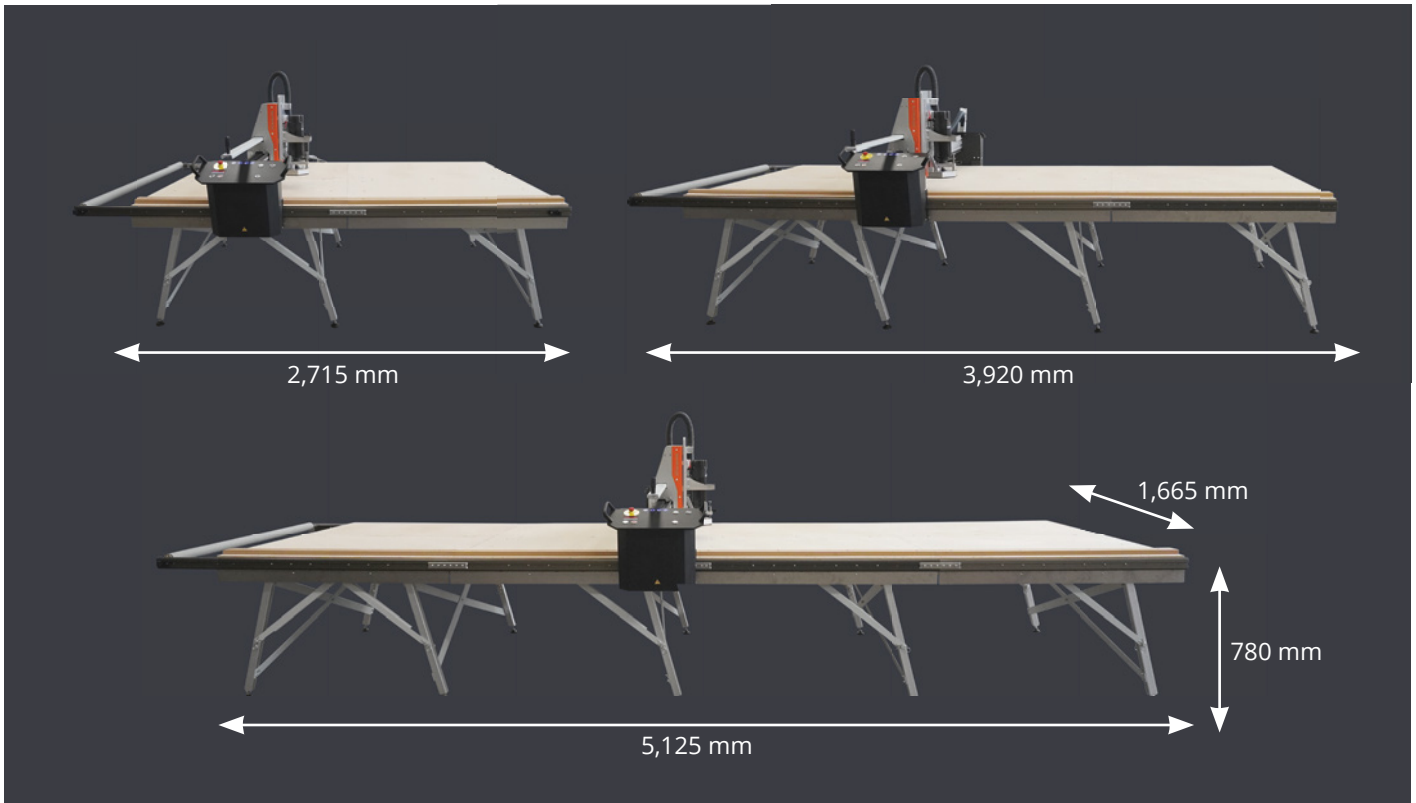

Table dimensions

- modular setup:
 - length: 2,715 mm (incl. 1 extension module)
 - width: 1,665 mm (2,080 mm inkl. portal)
 - height: 780 mm (working top)
- each extension module:
 - length: plus 1,205 mm

Board processing dimensions

- Cutting length: 2,100 mm
 - for 2 m panels (basic table + extension)
 - for 3 m panels (+ 1 extension)
 - for 2x 2 m panels (+ 2 extensions)
 - for 2 m + 3 m panels (+ 3 extensions)
 - etc.
- Cutting width: 1,205 mm
- Cutting depth: 62 mm
- per extension: 1,205 mm

Areas of application

- round arches
- ceiling truncations
- light coves
- niches (for showers etc.)
- boxes
- window reveals
- free-standing wall ends
- cladding for beams, pipes, supports, girders etc.

Board materials

- alucobond
- aluminium composite panels
- fire protection panels
- eternit boards
- fibre composite panels
- Fermacell boards
- wood / wood composite panels
- insulating panels
- calcium silicate boards
- laminate / parquet
- MDF boards
- multilayer boards
- OSB boards
- Shuttering boards
- Dry subfloor

Accessories

- extension table modules to increase the working area (each 1,205 mm long)
- powerful milling and sawing units with different variants
- high-quality tools (milling cutters, saw blades, copying modules, guides etc.)
- powerful extraction systems
- professional gluing systems
- profile elements made of aluminum to complement the portfolio

Leasing and financing offers that are individually and precisely tailored to your needs enable a quick return on investment for your machine.

We will be happy to advise you personally on this!

Of course also on topics such as workplace planning, production of prefab moulded parts, possible accessories etc.



We are looking forward to getting in touch with you!

flextos GmbH
Rosenheimer Strasse 44
83064 Raubling, Germany

Phone: +49 8031 2338860
info@flextos.com
www.flextos.com

